



Astra Wash7Pix

7x40W RGBW moving wash light with
4°-59° zoom and pixel control



USER MANUAL

Thank you for choosing PROLIGHTS

Please note that every PROLIGHTS product has been designed in Italy to meet quality and performance requirements for professionals and designed and manufactured for the use and application as shown in this document.

Any other use, if not expressly indicated, could compromise the good condition/operation of the product and/or be a source of danger.

This product is meant for professional use. Therefore, commercial use of this equipment is subject to the respectively applicable national accident prevention rules and regulations.

Features, specifications and appearance are subject to change without notice. Music & Lights S.r.l. and all affiliated companies disclaim liability for any injury, damage, direct or indirect loss, consequential or economic loss or any other loss occasioned by the use of, inability to use or reliance on the information contained in this document.

Product user manual can be downloaded from the website www.prolights.it, or can be inquired to the official PROLIGHTS distributors of your territory (https://www.prolights.it/sales_network.html).

Scanning the below **QR Code**, you will access the download area of the product page, where you can find a broad set of always updated technical documentation: specifications, user manual, technical drawings, photometrics, personalities, fixture firmware updates.

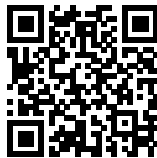

Visit the download area
of the product page



The PROLIGHTS Logo, PROLIGHTS names and all other trademark in this document pertaining to PROLIGHTS services or PROLIGHTS product are trademarks OWNED or licensed by Music & Lights S.r.l., its affiliates, and subsidiaries. PROLIGHTS is a registered trademark by Music & Lights S.r.l. All right reserved. Music & Lights – Via A. Olivetti, snc - 04026 - Minturno (LT) ITALY.

INDEX

SAFETY INFORMATION	02
1 - PACKAGING	05
PACKAGE CONTENT	05
OPTIONAL ACCESSORIES	05
2 - TECHNICAL DRAWING	05
3 - INSTALLATION	06
MOUNTING	06
4 - CONNECTION TO THE MAINS SUPPLY	07
5 - START UP	07
CONNECT AND DISCONNECT POWER FROM THE PRODUCT	07
6 - PRODUCT OVERVIEW	08
7 - DMX CONNECTION	09
CONNECTION OF THE CONTROL SIGNAL: DMX LINE	09
INSTRUCTIONS FOR A RELIABLE DMX CONNECTION	09
CONNECTION DAISY CHAIN	09
CONNECTION OF THE DMX LINE	09
CONSTRUCTION OF THE DMX TERMINATION	10
DMX ADDRESSING	10
ETHERNET CONNECTION	10
ETHERNET OPERATION	10
ETHERNET TO DMX OPERATIONS	11
OPERATION AS A WIRELESS TRANSMITTER	11
IN TO WDMX	11
OPERATION AS A WIRELESS RECEIVER	12
WDMX TO DMX (RX)	12
8 - CONTROL PANEL	13
DISPLAY AND BUTTONS LAYOUT	13
9 - MENU STRUCTURE	14
10 - SHORTCUT	18
11 - RDM FUNCTIONS	19
12 - DMX CHARTS	21
FIXTURE ENGINE	21
13 - RING LAYOUT	27
14 - PIXEL LAYOUT	27
15 - ERROR MESSAGES	28
IDENTIFICATION OF ELECTRONIC BOARDS	29
16 - ACCESSORIES INSTALLATION	30
EGG CRATE (ASTRAW7PEC - OPTIONAL)	30
17 - PERIODICAL CLEANING	31
18 - MAINTENANCE	32
MAINTENANCE AND CLEANING THE PRODUCT	32
REPLACING THE FUSE	32
VISUAL CHECK OF PRODUCT HOUSING	32
TROUBLESHOOTING	33

SAFETY INFORMATION



WARNING!

- See <https://www.prolights.it/product/ASTRAWASH7PIX#download> for installation instructions.
- Please read carefully the instruction reported in this section before installing, powering, operating or servicing the product and observe the indications also for its future handling.



This unit is not for household and residential use, only professional applications.



Connection to mains supply

- The Connection to the mains supply must be carried out by a qualified electrical installer.
- Use only AC supplies 100-240V 50-60 Hz, the fixture must be electrically connected to ground (earth).
- Select the cable cross section in according with the maximum current draw of the product and the possible number of products connected at the same power line.
- The AC mains power distribution circuit must be equipped with magnetic+residual current circuit breaker protection.
- Do not connect it to a dimmer system; doing so may damage the product.



Protection and Warning against electrical shock

- Do not remove any cover from the product, always disconnect the product from AC power before servicing.
- Ensure that the fixture is electrically connected to ground (earth). And use only a source of AC power that complies with local building and electrical codes and has both overload and ground-fault (earth-fault) protection.
- Before using the fixture, check that all power distribution equipment and cables are in perfect condition and rated for the current requirements of all connected devices.
- Isolate the fixture from power immediately if the power plug or any seal, cover, cable, or other components are damaged, defective, deformed or showing signs of overheating.
- Do not reapply power until repairs have been completed.
- Refer any service operation not described in this manual to PROLIGHTS Service team or an authorized PROLIGHTS service center.



Installation

- Make sure that all visible parts of the product are in good visible condition before its use or installation.
- Make sure the point of anchorage is stable before positioning the projector.
- When suspending the fixture above ground level, secure it against failure of primary attachments by attaching a safety cable that is approved as a safety attachment for the weight of the fixture to the attachment point on the main frame of the product. In case the safety cable, enter in action, it needs to be replaced with a new one.
- Install the product only in well ventilated places.
- For non temporary installations, ensure that the fixture is securely fastened to a load-bearing surface with suitable corrosion-resistant hardware.
- For a temporary installation with clamps, ensure that the quarter-turn fastener and/or screws are turned fully, and secured with a suitable safety cable.



Minimum distance of illuminated objects

- The projector needs to be positioned so that the objects hit by the beam of light are at least 0.3 meters (0.98 ft) from the lens of the projector.

T_a 45°C

Max operating ambient temperature (T_a)

- Do not operate the fixture if the ambient temperature (T_a) exceeds 45 °C (113 °F).

T_a -10°C

Minimum operating ambient temperature (T_a)

- Do not operate the fixture if the ambient temperature (T_a) is below -10 °C (14 °F).



Protection from burns and fire

- The exterior of the fixture becomes hot during use. Avoid contact by persons and materials.
- Ensure that there is free and unobstructed airflow around the fixture.
- Keep flammable materials well away from the fixture.
- Do not expose the front glass to sunlight or any other strong light source from any angle. Lenses can focus the sun's rays inside the fixture, creating a potential fire hazard.
- Do not attempt to bypass thermostatic switches or fuses.



Indoor use

- This product is designed for indoor and dry environments.
- Do not use in wet location and do not expose the fixture to rain or moisture.
- Never use the fixture in places subject to vibrations or bumps.
- Make certain that no inflammable liquids, water or metal objects enter the fixture.
- Excessive dust, smoke fluid, and particle build up degrades performance, causes overheating and will damage the fixture.
- Damages caused by inadequate cleaning or maintenance are not covered by the product warranty.



Light collimation optical system

- This product contains internal light collimation optical system. Avoid to expose the optical system to any intense source of light (including sunlight) from any angle.

T_c 70°C

Temperature of the external surface

- The surface of the fixture can reach up to 70 °C (158 °F) during operation. Avoid contact with people and materials.



Radio receiver

This product contains a radio receiver and/or transmitter:

- Maximum output power: 17 dBm.
- Frequency band: 2.4 GHz.



Maintenance

- Warning! Disconnect the fixture from AC mains power and allow to cool for at least 10 minutes before handling.
- Only technicians who are authorized by PROLIGHTS or Authorised service partners are permitted to open the fixture.
- Users may carry out external cleaning, following the warnings and instructions provided, but any service operation not described in this manual must be referred to a qualified service technician.
- Important! Excessive dust, smoke fluid, and particle build up degrades performance, causes overheating and will damage the fixture. Damages caused by inadequate cleaning or maintenance is not covered by the product warranty.



Photobiological safety

- This device emits potentially dangerous optical radiation and is identified in the category of Risk Group 2 according to EN 62471.



Do not stare at the operating light source

- Do not look directly at the LED source during operation. It can be harmful to the eyes and skin.
- During Installation, operation and maintenance, be prepared for the fixture to light and move suddenly when connected to power.
- The device should be positioned so that prolonged staring into the luminaire at a distance closer than 1.772 m (5.813 ft) is not expected.

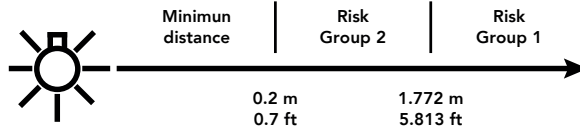

Disposal

- This product is supplied in compliance with European Directive 2012/19/EU – Waste Electrical and Electronic Equipment (WEEE). To preserve the environment please dispose/ recycle this product at the end of its life according to the local regulation.



The product contains a lithium ion battery

- Don't throw the unit into the garbage at the end of its lifetime.
- Make sure to dispose according to your local ordinances and/or regulations, to avoid polluting the environment!
- The packaging is recyclable and can be disposed.



The products to which this manual refers comply with:

- 2014/35/EU - Safety of electrical equipment supplied at low voltage (LVD).
- 2014/30/EU - Electromagnetic Compatibility (EMC).
- 2011/65/EU - Restriction of the use of certain hazardous substances (RoHS).
- 2014/53/EU - Radio Equipment Directive (RED).



The products to which this manual refers comply with:

- UL 1573 + CSA C22.2 No. 166 - Stage and Studio Luminaires and Connector Strips.
- UL 1012 + CSA C22.2 No. 107.1 - Standard for power units other than class 2.



FCC Compliance:

- This device complies with Part 15 of the FCC Rules. Operation is subject to the following two conditions:
 1. This device may not cause harmful interference, and
 2. This device must accept any interference received, including interference that may cause undesired operation.



Other approvals

1 - PACKAGING

PACKAGE CONTENT

- 1x ASTRAWASH7PIX;
- 1x 1,5 meters power cable (BARE END - NEUTRIK POWERCON TRUE1 IP65);
- 1x OS24;
- User Manual.

OPTIONAL ACCESSORIES

- WSBBR512G6: blackBox R-512 G6 receiver 512Ch, 2.45GHz,DMX&RDM,Bluetooth,G3,G4,G4S,G5,CRMX;
- WSBBR512G5: blackBox R-512 G5 receiver 512Ch, 2.45GHz & 5.8GHz, DMX/RDM optional;
- WSBBF1G6: blackBox F-1 G6 transrec, 512ch, 2.45GHz, DMX&RDM,Bluetooth,G3,G4,G4S, G5, CRMX;
- WSBBF1G5: blackBox F-1 G5 transmitter, 2,45GHz & 5.2/5,8 GHz, DMX/RDM, 512Ch;
- TOUR53415L03BK: dmx cable HC5340. CANC5MXX XLR 5p->CANC5FXX XLR (f) 5p, L.3m;
- 958225L03: 3x2.5mm TH07 Cable, 16A 3p PwCon MXW, 16A 3p PwCon FXW, L. 3m;
- 9513FXWL03: ass. 3x2.5mm TH07 cable, 16A 3p 230V CEE plug, MENAC3FXW socket, L.3 m;
- 9533FXWL03: ass. 3x2.5mm TH07 cable, SHUKO plug, MENAC3FXW socket, L.3m;
- RSR0630A/B: Steel security cable for hanging bodies, inox steel shackle, L=60 cm, silver/black;
- C6002: Slim aluminium clamp, 200 kg loading, 48-51 mm tubes, M10 bolt;
- OS24: quick-lock omega bracket;
- FCLASTRAW7PIX: flight case for 6 pcs of ASTRAWASH7PIX;
- ASTRAW7PEC: egg crate for ASTRAWASH7PIX;
- UPBOX2: Firmware uploader kit, USB IN, 3-pin XLR DMX OUT.

2 - TECHNICAL DRAWING

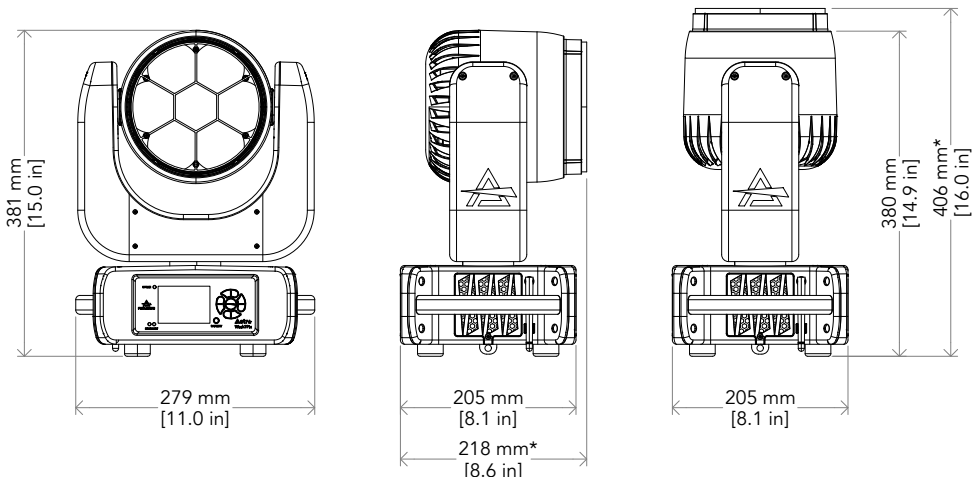

* The measures include the zoom.

Weight: 8.1 kg - 17.85 lbs

Fig. 01

3 - INSTALLATION

MOUNTING

Check that the supporting structure can safely bear the weight of all installed fixtures, clamps, cables, auxiliary equipment, etc. and complies with locally applicable regulations.

When suspending the fixture above ground level, secure it against failure of primary attachments by attaching a safety wire that is approved as a safety attachment for the weight of the fixture to an anchor point on the product main frame.

Do not use removable parts or weak anchors for secondary attachment.

Warning! When clamping the fixture to a truss or other structure at any angle, use clamps of half-coupler type. Do not use any type of clamp that does not completely encircle the structure when fastened.

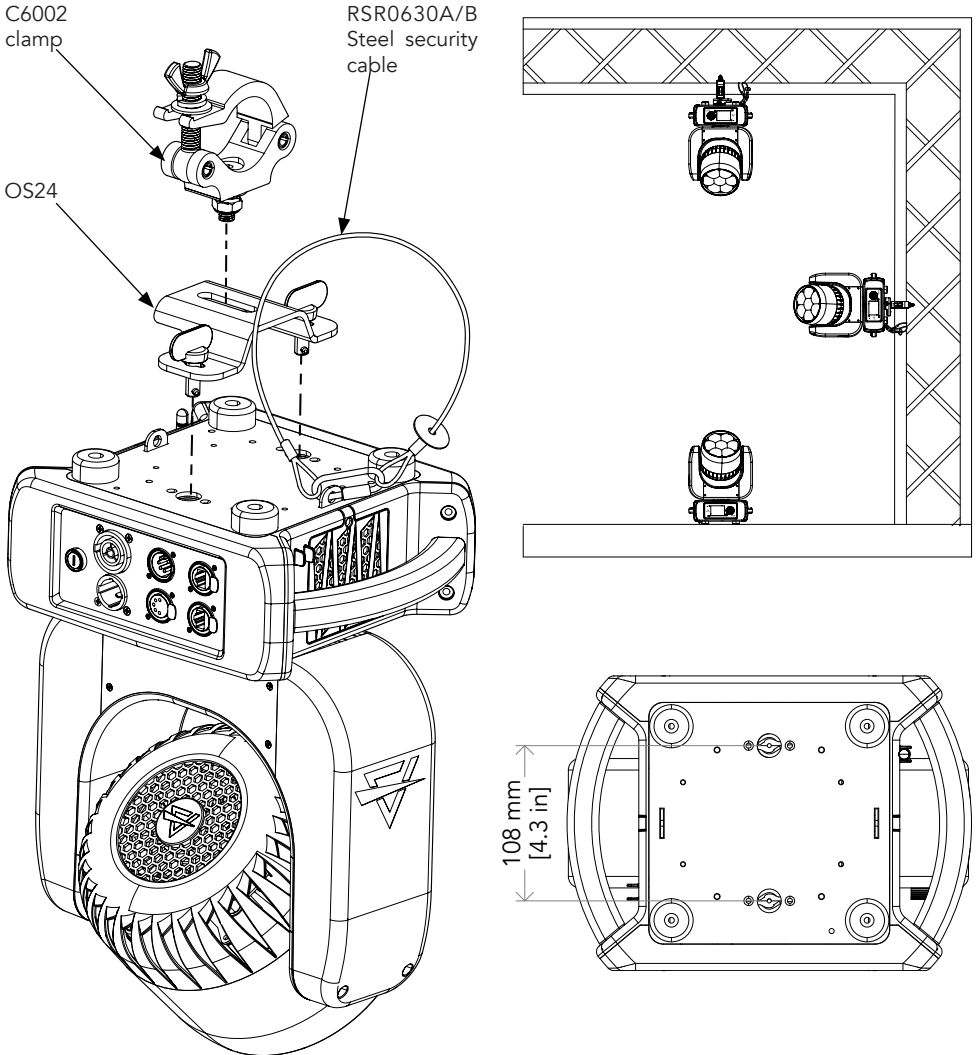

Fig. 02

4 - CONNECTION TO THE MAINS SUPPLY

WARNING: For protection from electric shock, the fixture must be earthed!

The product is equipped with auto-switching power supply that automatically adjusts to any 50-60Hz AC power source from 100-240 Volts.

If you need to install a power plug on the power cable to allow connection to power outlets, install a grounding-type (earthed) plug, following the plug manufacturer's instructions. If you have any doubts about proper installation, consult a qualified electrician.

The max power consumption is 225W.

Core (EU)	Core (US)	Connection	Plug terminal marking
Brown	Black	Live	L
Blue	White	Neutral	N
Yellow+green	Green	Earth	

5 - START UP

CONNECT AND DISCONNECT POWER FROM THE PRODUCT

To apply and disconnect power to the product:

- Check that the product is installed and secured as indicated in the Safety Informations, and that personal safety will not be put at risk when the fixture lights up.
- Connect the power connector into the Mains input socket (100-240 VAC-50/60 Hz).
- The product is then ready for its operations and can be controlled through the available input signals on board.
- To disconnect power from the product, disconnect the Mains from the socket.

6 - PRODUCT OVERVIEW

1. SAFETY EYE to attach safety cable;
2. USER INTERFACE with display and buttons for access to the control panel functions;
3. ETHERCON CONNECTORS IN / OUT signal;
4. DMX IN (5-p XLR): 1 = GND, 2 = sign-, 3 = sign+, 4 N/C, 5 N/C;
5. DMX OUT (5-p XLR): 1 = GND, 2 = sign-, 3 = sign+, 4 N/C, 5 N/C;
6. POWER IN: for connection to the Mains 100-240V~/50-60Hz;
7. POWER OUT: power output for connection of multiple units in series;
8. MAIN FUSE HOLDER: replace a burnt-out fuse by one of the same type only (T3.15A 250V);
9. ANTENNA of Wireless DMX Receiver internal module.

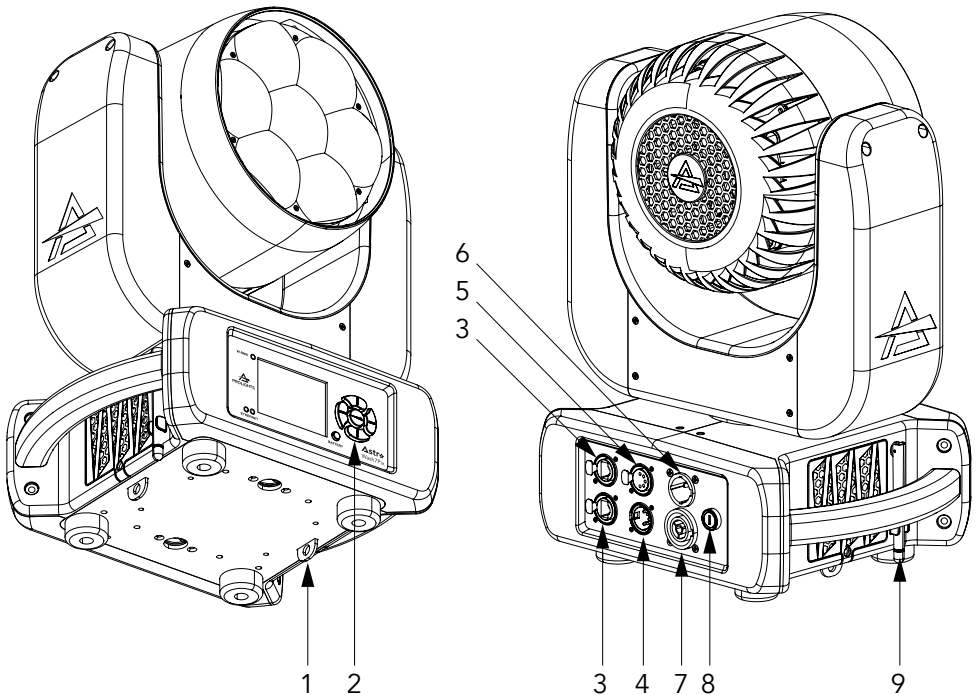

Fig. 03

7 - DMX CONNECTION

CONNECTION OF THE CONTROL SIGNAL: DMX LINE

The product has XLR sockets for DMX input and output.

The default pin-out on both socket is as the following diagram:

DMX - INPUT XLR plug

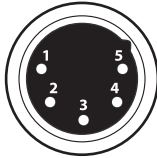

- Pin1 : GND - Shield
- Pin2 : - Signal
- Pin3 : + Signal
- Pin4 : N/C
- Pin5 : N/C

DMX - OUTPUT XLR socket

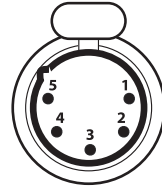

Fig. 04

INSTRUCTIONS FOR A RELIABLE DMX CONNECTION

Use shielded twisted-pair cable designed for RS-485 devices: standard microphone cable cannot transmit control data reliably over long runs. 24 AWG cable is suitable for runs up to 300 meters (1000 ft). Heavier gauge cable and/or an amplifier is recommended for longer runs.

To split the data link into branches, use splitter-amplifiers in the connection line.

Do not overload the link. Up to 32 devices may be connected on a serial link.

CONNECTION DAISY CHAIN

Connect the DMX data output from the DMX source to the product DMX input (male connector XLR) socket.

Run the data link from the product XLR output (female connector XLR) socket to the DMX input of the next fixture.

Terminate the data link by connecting a 120 Ohm signal termination. If a splitter is used, terminate each branch of the link.

Install a DMX termination plug on the last fixture on the link.

CONNECTION OF THE DMX LINE

DMX connection employs standard XLR connectors. Use shielded pair-twisted cables with 120Ω impedance and low capacity.

The following diagram shows the connection mode:

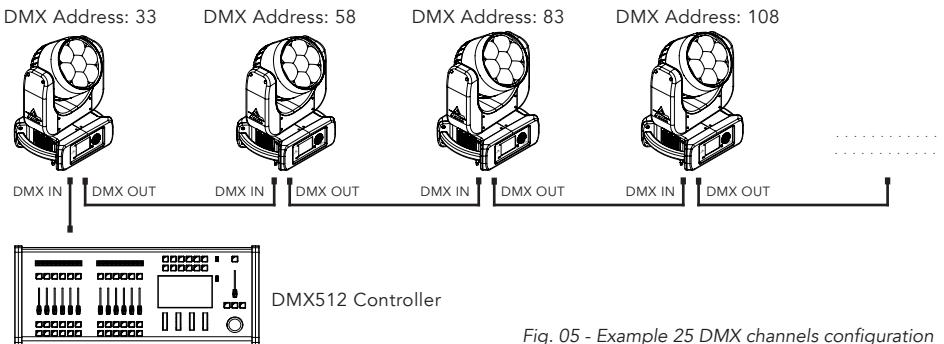

Fig. 05 - Example 25 DMX channels configuration

CONSTRUCTION OF THE DMX TERMINATION

The termination is prepared by soldering a 120Ω 1/4 W resistor between pins 2 and 3 of the male XLR connector, as shown in figure.

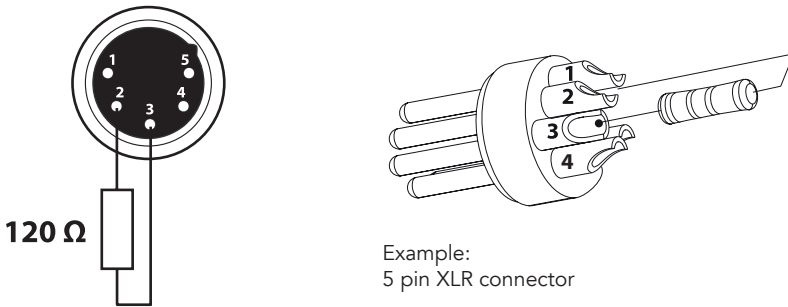

Fig. 06

DMX ADDRESSING

In order to start controlling the product via DMX, the first step is to select a DMX address, also known as the start channel, this is the first channel used to receive instructions from a DMX controller. If you wish to control the product individually, it is necessary to assign a different starting address channel to each fixture.

The number of channels occupied from the product depends on the DMX mode selected, so always verify the DMX Mode in the MENU before start addressing.

If you assign two fixtures the same address, they will be executing the same behaviour. Selecting the same address to multiple fixtures can be useful for diagnostic purposes and symmetrical control.

DMX addressing is limited to make it impossible to set the DMX address so high that you are left without enough control channels for the product.

To set the fixture's DMX address:

1. Press ENTER to open the main menu.
2. Reach the addressing menu, then select the DMX ADDRESS settings.
3. Select the address from 1 to 512 using the navigation arrows/buttons and confirm by pressing ENTER.
4. Press Menu to exit and return to the Home screen.

ETHERNET CONNECTION

The product is provided with two 8-pin RJ-45 sockets for Ethernet input/output for a simple daisy chain connection to the network.

The product can be controlled with ArtNet/sACN/Klingnet communication protocol.

Use a network cable category 5 (with four "twisted" wire pairs) and standard RJ-45 plugs.

ETHERNET OPERATION

Please refer to the section MENU STRUCTURE contained in this document for detailed information about the parameters of setting on the fixture (Protocol, Net, Subnet, Universe, Start Channel and IP Address, Ethernet to DMX No/Yes).

- IP addresses recommended: 002.xxx.xxx.xxx or 010.xxx.xxx.xxx.
- The submask net is fixed at 255.0.0.0.

ETHERNET TO DMX OPERATIONS

Please refer to the section MENU STRUCTURE contained in this document for detailed informations. This function allow a product receiving an ethernet signal protocol to re-transmit the incoming signal onto a wired DMX line through its onboard XLR-out connector.

- An Ethernet protocol (Artnet, sACN or others available) has to be enabled from Ethernet menu at first fixture. **Please make sure that wireless receiver is switched to OFF if you use Ethernet communication.**
- Enable the option Ethernet To DMX choosing which fixture needs to be retransmitted (Main Fixture or Pixel Engine) from the Ethernet menu at the first product (connected to the Ethernet) in the signal chain, next products have standard DMX setting.
- Connect the Ethernet input of the first product in the data chain with the network. Connect the DMX output of this product with the input of the next product until all products are connected to the DMX chain.
- Caution: At the last product, the DMX chain has to be terminated with a terminator. Solder a 120 Ω resistor between Signal (-) and Signal (+) into a XLR-plug and connect it in the DMX-output of the last product.

OPERATION AS A WIRELESS TRANSMITTER

ASTRAWASH7PIX can be used as wireless transmitter to transmit DMX signal to different wireless receivers. To use ASTRAWASH7PIX as wireless transmitter, please follow the procedure below:

1. Push ENTER button untill you show CONNECT on display, then press ENTER button to confirm.
 2. Use UP/DOWN buttons for select WIRELESS, then press ENTER to confirm.
 3. Push ENTER button on WDMX ON/OFF function and enable it to ON.
 4. Select WDMX mode and set it on Transmitter (please note that WDMX mode will be available only if WDMX ON/OFF is set to ON).
 5. Ensure that the receiver units are not connected to any other transmitter. Please refer to "Reset the receiver" paragraph.
 6. Enable TX LINK to ON to link transmitter to receivers (please note that TX LINK will be available only if WDMX mode is set to Transmitter).
- The transmitter scans for all unlinked receivers for a period of about 5 seconds.
 - If the connection fails, check the position of the receiver.
 - The wireless icon on the receiver display indicates the received signal strength.

Unlinking the transmitter

Follow the procedure below to unlink the transmitter from all receivers connected with the unit.

1. Push ENTER button untill you show CONNECT on display, then press ENTER button to confirm.
 2. Use UP/DOWN buttons for select Wireless, then press ENTER to confirm.
 3. Enable TX UNLINK to ON 8 (please note that TX UNLINK will be available only if WDMX mode is set to Transmitter).
- All connected receivers will be unlinked.

IN TO WDMX

This function enable or disable the transmission throught wireless of the DMX signal from the transmitter side to the receiver.

Any incoming signal (ArtNet, sACN or DMX) is retransmitted throught wireless.

If the ASTRAWASH7PIX protocol selected is ArtNet / sACN, the WDMX module will retransmit the DMX values contained in the ArtNet / sACN signal received from the ASTRAWASH7PIX.

NOTE: Artnet and sACN have higher priority on DMX if they are connected to transmitter.

NOTE: Do not use IN TO WDMX and ETH TO DMX simultaneously, this will cause data conflict on DMX output signal.

OPERATION AS A WIRELESS RECEIVER

ASTRAWASH7PIX can be used as wireless receiver connected to a wireless transmitter.

To use ASTRAWASH7PIX as wireless receiver, please follow the procedure below:

1. Push ENTER button until you show CONNECT on display, then press ENTER button to confirm.
2. Use UP/DOWN buttons for select Wireless, then press ENTER to confirm.
3. Push ENTER button on WDMX ON/OFF function and enable it to ON.
4. Select WDMX mode and set it on Receiver (please note that WDMX mode will be available only if WDMX ON/OFF is set to ON).
5. Enable RX RESET to ON to reset the receiver (please note that RX RESET will be available only if WDMX mode is set to Receiver).
6. On the transmitter, enable TX LINK to ON to link transmitter to the receivers.
7. If the connection is successful and DMX input is available the display the display on the receiver unit will shows the DMX address. If DMX signal is not available, the display will shows "No signal" but keeps the transmitter linked.
8. If the connection fails, check the position of the receiver.
9. The wireless icon on the receiver display indicates the received signal strength.

Reset the receiver

Follow the procedure below to reset the receiver.

1. Push MENU button until you show CONNECT on display, then press ENTER button to confirm.
2. Use UP/DOWN buttons for select Wireless, then press ENTER to confirm.
3. Enable RX RESET to ON.
 - The wireless icon on the receiver display indicates the received signal strength.

WDMX TO DMX (RX)

This function enable or disable the retransmission of the wireless DMX signal received through the DMX port on the receiver side.

8 - CONTROL PANEL

The product has a display and buttons for access to the control panel functions.

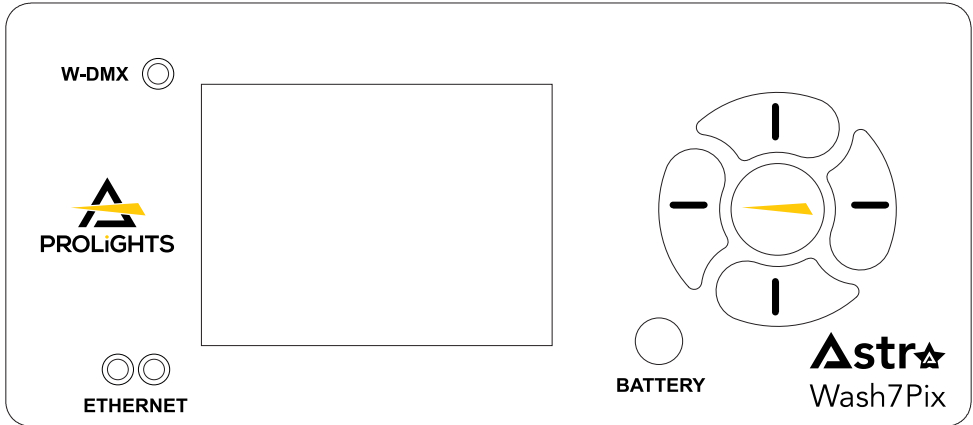

Fig. 07

DISPLAY AND BUTTONS LAYOUT

The product has a display and buttons for access to the control panel functions:

	<p>1 </p> <p>2 </p> <p>3 </p> <p>4 </p> <p>5 </p>	<ul style="list-style-type: none"> • Browse upwards through the menu list and increases the numeric value displayed. • Scroll from left to right when entering numerical values, switching between hundreds, tens and units • Browse downwards through the menu list and decreases the numeric value displayed. • Return to the top level, or scroll from right to left when entering numerical values, switching between units, tens and hundreds • Used to confirm the displayed value, or activate the displayed function or to access the menu tree or to return a previous menu window.
<p>BATTERY </p>	<ul style="list-style-type: none"> • Switch on the display using backup battery. Hold for 5s. • Switch off display by pressing button 4 for 5s while on being on Home screen. 	
<p>W-DMX </p>	<ul style="list-style-type: none"> • LED indicator for Wireless dmx (color red and green). 	
<p> ETHERNET</p>	<ul style="list-style-type: none"> • LED indicator for Ethernet network.(color orange). 	

9 - MENU STRUCTURE

The following chart describes the MENU tree of the product, the terms shown in **BOLD** indicates the default settings.

MENU						
1	CONNECT	ADDRESS	FIXTURE	DMX / WDMX	001-512	Set address used for Fixture and for Pixel patch.
				sACN		
				ARTNET		
		PIXELS	FOLLOW FIXTURE	001-512		
			DMX / WDMX			
			sACN			
			ARTNET			
			sACN + KLINGNET			
		DMX MODE	FIXTURE	BASIC FX STANDARD EXTENDED	Set DMX chart for Main Fixture.	
			PIXELS	OFF RING PIXELS	Set DMX chart for Pixel Fixture.	
	WIRELESS	WDMX ON/OFF	ON/ OFF	Enable/Disable the wireless card.		
		WDMX MODE	TRANSMITTER/ RECEIVER	Allows to choose whether to set the wireless on the Transmitter or Receiver. WDMX mode is unlocked only if WDMX ON / OFF is ON.		
		TX LINK	ON/ OFF	TX link unlock when the unit is set as a transmitter..		
		TX UNLINK	ON/ OFF	Disconnect the transmitter from all receivers. TX unlink unlocks only if WDMX mode is on transmitter		
		RX RESET	ON/ OFF	Total reset of the receiver. RX reset unlocks only if WDMX mode is receiver.		
		IN TO WDMX (TX)	OFF MAIN FIXTURE TO WDMX PIXEL ENGINE TO WDMX	Enable/Disable the transmission of the DMX values via wdmx. Main Fixture to WDMX: transmitt main fixture DMX values Pixel Engine to WDMX: transmitt pixel engine dmx values		
		WDMX TO DMX (RX)	ON/ OFF	Enable/Disable the retransmission of the DMX from the receiver to the other units connected by cable to the receiver itself.		
	ETHERNET SETTING	ARTNET SETTINGS	IP ADDRESS NET SUBNET UNIVERSE	Set IP address of the fixture. Set Net for ArtNet protocol. Set Subnet for ArtNet protocol. Set Universe for ArtNet protocol.		
		sACN SETTINGS	IP ADDRESS UNIVERSE	Set IP address of the fixture. Set Universe for sACN protocol.		
			MERGE MODE	OFF /HTP/ LTP	Set Merge Mode for sACN protocol.	
		ETHERNET TO DMX	ON OFF	Enable / Disable DMX retransmission from sACN/ArtNet signal to DMX out port.		
		KLINGNET	ON OFF	Enable / Disable Klingnet functionality for sACN / ArtNet protocols.		

2	SETUP	SCREEN	BACKLIGHT	ON 10 s 20 s 30 s	Allows you to select the timing after that display will switch automatically off when unactive.
			FLIP DISPLAY	ON OFF AUTO	Allows you to rotate the display by 180°.
			KEY LOCK	ON OFF	Allows you lock the buttons on the control panel by a password. Press following combinations (password) in order to access to the user menu : UP, DOWN, UP, DOWN.
		MOVEMENT	PAN REVERSE	ON OFF	Allows you to reverse Pan movement.
			TILT REVERSE	ON OFF	Allows you to reverse Tilt movement.
			PAN/TILT FEEDBACK	ON OFF	To activate / deactivate the reading of the feedbacks given by the encoders.
			PAN/TILT MODE	SLOW MEDIUM FAST SYNC	To choose the horizontal/vertical movement speed. SYNC mode will sync movement speed with the whole ASTRAWASH family fixtures.
			HOME POSITION	STANDARD CUSTOM	To choose the home position.
			CUSTOM P DEGREE	0° ... 315°	To choose pan values in case of Custom position.
			CUSTOM T DEGREE	0% ... 100%	To choose tilt values in case of Custom position.
		FIXTURE SETTINGS	FAN MODE	AUTO SILENT HIGH	Select Fan behaviour.
			TUNGSTEN EMULATION	ON/OFF	
			WHITE CALIBRATION	OFF STUDIO 8000K	Manufacturer calibration to grant performance and color consistency.
			DMX FAULT	HOLD BLACKOUT	To choose the behaviour of fixture in case of dmx signal lost.
			SAFE POSITIONING	ON OFF	Zoom Lenses autoretract after 30s of DMX Lost.
			STATUS LED	ON OFF	To turn the status LEDs on the front panel on or off.
			ZOOM MODE	STANDARD PIXELS	Select zoom mode.
			DIMMER CURVE	LINEAR S-CURVE SQUARE LAW INV. SQUARE LAW	Select different curve behaviour of dimmer.
			DIMMER SPEED	AUTO FAST MEDIUM SLOW	Linear dimmer behaviour. Dimmer curve adding long fade. Dimmer curve adding medium fade. Dimmer curve adding little fade.
			LED FREQUENCY	600Hz 1200Hz 2000Hz 4000Hz 6000Hz 25KHz 50KHz	Select PWM frequency.
			INVERT MAPPING	ON OFF	Invert mapping for Pixel fixture.
INVERT ZOOM	ON OFF	Invert zoom values.			
TRANSFER CONFIGURATION	WITHOUT DMX ADDRESS WITH DMX ADDRESS	To transfer the same menu settings of one fixtures to all the other in the daisy chain, including or not the dmx address.			

3	ADVANCED	RESET	ALL PAN & TILT ... ZOOM		To reset these functions.
		CALIBRATION	PASSWORD PAN TILT ...		For the calibration of these functions. 050 password for user reset.
		MANUAL CONTROL	PAN ...		For manual control of the unit.
		RELOAD DEFAULT	BASIC RELOAD	ON OFF	050 password for user reset.
			FACTORY RELOAD	ON OFF	
4	INFORMATION	FIXTURE TIME	FIXTURE HOURS	TOTAL (ONLY READ)	To check the total working hours of the unit.
				PARTIAL (READ AND RESET)	
			CURRENT HOURS	TOTAL (ONLY READ)	To check the current working hours of the unit.
				PARTIAL (READ AND RESET)	
			SOURCE HOURS	TOTAL (ONLY READ)	To see the total operating hours of the LED source.
		PARTIAL (READ AND RESET)			
		POWER ON CYCLE	TOTAL (ONLY READ)	To see the power cycles of the machine.	
			PARTIAL (READ AND RESET)		
		MAINTENANCE TIME	TOTAL (ONLY READ)	To choose and reset unit maintenance warning hours.	
			PARTIAL (READ AND RESET)		
		TEMPERATURE	NEAR SOURCE TEMP, DRIVER PCB TEMP, LED PCB TEMP,...		To see the unit temperature.
		FANS SPEED	NEAR SOURCE FAN, BASE FAN,...		To see the speed of the fans.
		WIRELESS QUALITY			To check the wireless quality.
		CHANNEL VALUE	PAN...		To see the dmx value of those channels.
		ERROR MESSAGE	PAN, TILT...		To see any error messages.
		FIXTURE MODEL	XXXXXXXXXX		View informations about fixture model.
		RDM UID	(READ AND RESET)		View ID for the RDM control.
		SOFTWARE VERSION	1U01 V1.0.00...		View informations about software version.

10 - SHORTCUT

KEYS	MODE	DESCRIPTION
UP + DOWN after power on	Flip Display	Directly flip display without enter inside menu.
DOWN then power on	Reset without pan/tilt movements	Fixture will be powered on without reset on pan/tilt movements.
ENTER + UP then power on	Bootloader	Force firmware upgrade.

11 - RDM FUNCTIONS

The product can communicate using RDM (Remote Device Management) protocol over a DMX512 Networks.

RDM is a bi-directional communications protocol for use in DMX512 control systems, it is the open standard for DMX512 device configuration and status monitoring.

The RDM protocol allows data packets to be inserted into a DMX512 data stream without affecting existing non-RDM equipment. It allows a console or dedicated RDM controller to send commands to and receive messages from specific fixtures.

The PIDs in the following tables are supported in the product.

RDM is also available on Wireless and Tiny's Downstead must be enabled in its custom PIDs to work.

Category	Parameter	PID	GET	SET
Product Information	DEVICE_INFO	0x0060	x	
	PRODUCT_DETAIL_ID_LIST	0x0070	x	
	DEVICE_MODEL_DESCRIPTION	0x0080	x	
	MANUFACTURER_LABEL	0x0081	x	
	DEVICE_LABEL	0x0082	x	x
	FACTORY_DEFAULTS	0x0090	x	x
	SOFTWARE_VERSION_LABEL	0x00C0	x	
	BOOT_SOFTWARE_VERSION_ID	0x00C1	x	
	BOOT_SOFTWARE_VERSION_LABEL	0x00C2	x	
DMX512 Setup	DMX_PERSONALITY	0x00E0	x	x
	DMX_PERSONALITY_DESCRIPTION	0x00E1	x	
	DMX_START_ADDRESS	0x00F0	x	x
	SLOT_INFO	0x0120	x	
	SLOT_DESCRIPTION	0x0121	x	
	DEFAULT_SLOT_VALUE	0x0122	x	
	DMX_BLOCK_ADDRESS	0x0140	x	x
	DMX_FAIL_MODE	0x0141	x	x
	DMX_STARTUP_MODE	0x0142	x	x
Dimmer Settings	DIMMER_INFO	0x0340	x	
	MINIMUM_LEVEL	0x0341	x	x
	MAXIMUM_LEVEL	0x0342	x	x
	CURVE	0x0343	x	x
	CURVE_DESCRIPTION	0x0344	x	x
	OUTPUT_RESPONSE_TIME	0x0345	x	x
	OUTPUT_RESPONSE_TIME_DESCRIPTION	0x0346	x	
	MODULATION_FREQUENCY	0x0347	x	x
	MODULATION_FREQUENCY_DESCRIPTION	0x0348	x	
Sensors	SENSOR_DEFINITION	0x0200	x	
	SENSOR_VALUE	0x0201	x	x
	RECORD_SENSORS	0x0202		x
	BURN_IN	0x0440	x	x

Category	Parameter	PID	GET	SET
Power/Lamp Settings	DEVICE_HOURS	0x0400	x	x
	LAMP_HOURS	0x0401	x	x
	LAMP_STRIKES	0x0402	x	x
	LAMP_STATE	0x0403	x	x
	LAMP_ON_MODE	0x0404	x	x
	DEVICE_POWER_CYCLES	0x0405	x	x
Display Settings	DISPLAY_INVERT	0x0500	x	x
	DISPLAY_LEVEL	0x0501	x	x
Configuration	PAN_INVERT	0x0600	x	x
	TILT_INVERT	0x0601	x	x
	PAN_TILT_SWAP	0x0602	x	x
	REAL_TIME_CLOCK	0x0603	x	x
	LOCK_PIN	0x0640	x	x
	LOCK_STATE	0x0641	x	x
	LOCK_STATE_DESCRIPTION	0x0642	x	
Control	IDENTIFY_DEVICE	0x1000	x	x
	RESET_DEVICE	0x1001		x
	POWER_STATE	0x1010	x	x
	PERFORM_SELFTEST	0x1020	x	x
	SELF_TEST_DESCRIPTION	0x1021	x	
	CAPTURE_PRESET	0x1030	x	x
	PRESET_PLAYBACK	0x1031	x	x
	IDENTIFY_MODE	0x1040	x	x
	PRESET_INFO	0x1041	x	
	PRESET_STATUS	0x1042	x	x
	PRESET_MERGEMODE	0x1043	x	x
	POWER_ON_SELF_TEST	0x1044	x	x
	IP & DNS Configuration	IPV4_CURRENT_ADDRESS	0x0705	x
IPV4_STATIC_ADDRESS		0x0706	x	x
Custom Pids	FIX. ENGINE PROT. (0:W/DMX 1:sACN 2:ArtNet)	0x8010	x	x
	PIX. ENGINE PROT. (0:W/DMX 1:sACN 2:ArtNet 3:sAK 4:ArtK 5:K 6:sAN)	0x8020	x	x
	PIX. ENGINE ADDR. (1-512)	0x8030	x	x
	PIX. ENGINE MODE (0:Off 1:Ring 2:Pixel)	0x8040	x	x
	KLINGNET (0:Off 1:On)	0x8050	x	x

12 - DMX CHARTS

Fixture Engine

Ch	Basic	FX	FX 2	Standard	Extended	Extended 2
1	Pan	Pan	Pan	Pan	Pan	Pan
2	Pan Fine	Pan Fine	Pan Fine	Pan Fine	Pan Fine	Pan Fine
3	Tilt	Tilt	Tilt	Tilt	Tilt	Tilt
4	Tilt Fine	Tilt Fine	Tilt Fine	Tilt Fine	Tilt Fine	Tilt Fine
5	Dimmer	Dimmer	Dimmer	Dimmer	Dimmer	Dimmer
6	Dimmer Fine	Dimmer Fine	Dimmer Fine	Dimmer Fine	Dimmer Fine	Dimmer Fine
7	Shutter / Strobe	Shutter / Strobe	Shutter / Strobe	Shutter / Strobe	Shutter / Strobe	Shutter / Strobe
8	Red	Red	Red	Red	Red	Red
9	Green	Green	Green	Red Fine	Red Fine	Red Fine
10	Blue	Blue	Blue	Green	Green	Green
11	White	White	White	Green Fine	Green Fine	Green Fine
12	Color Macro	CCT	CCT	Blue	Blue	Blue
13	CCT	Zoom	Zoom	Blue Fine	Blue Fine	Blue Fine
14	Zoom	Crossfade Pixel Engine Protocol	Crossfade Pixel Engine Protocol	White	White	White
15	Crossfade Pixel Engine Protocol	Crossfade from Color to Pixel Engine	Crossfade from Color to Pixel Engine	White Fine	White Fine	White Fine
16	Crossfade from Color to Pixel Engine	Crossfade from White to Color	Crossfade from White to Color	Color Macro	Color Macro	Color Macro
17	Crossfade from White to Color	Control	Control	CCT	CCT	CCT
18	Control	Pattern	Pattern	Zoom	Zoom	Zoom
19		Pattern Speed	Pattern Speed	Zoom Fine	Zoom Fine	Zoom Fine
20		Pattern Fade	Pattern Fade	Crossfade Pixel Engine Protocol	Crossfade Pixel Engine Protocol	Crossfade Pixel Engine Protocol
21		Pattern Transition	Pattern Transition	Crossfade from Color to Pixel Engine	Crossfade from Color to Pixel Engine	Crossfade from Color to Pixel Engine
22		Foreground Intensity	Foreground Intensity	Crossfade from White to Color	Crossfade from White to Color	Crossfade from White to Color
23		Foreground Strobe	Foreground Strobe	Control	Control	Control
24		Background Intensity	Background Intensity	CTO on colors	CTO on colors	CTO on colors
25		Background Strobe	Background Strobe	Tint	Tint	Tint
26		Background Red	Background Red		Pattern	Pattern
27		Background Green	Background Green		Pattern Speed	Pattern Speed
28		Background Blue	Background Blue		Pattern Fade	Pattern Fade
29		Background White	Background White		Pattern Transition	Pattern Transition
30			Background Pattern		Foreground Intensity	Foreground Intensity

Fixture Engine

Ch	Basic	FX	FX 2	Standard	Extended	Extended 2
31			Background Pattern Speed		Foreground Strobe	Foreground Strobe
32			Background Pattern Fade		Background Intensity	Background Intensity
33					Background Strobe	Background Strobe
34					Background Red	Background Red
35					Background Green	Background Green
36					Background Blue	Background Blue
37					Background White	Background White
38						Background Pattern
39						Background Pattern Speed
40						Background Pattern Fade

Pixel Engine

Channel	Off	Ring	Pixel
1		Red 1	Red 1
2		Green 1	Green 1
3		Blue 1	Blue 1
4		White 1	White 1
5		Red 2	Red 2
6		Green 2	Green 2
7		Blue 2	Blue 2
8		White 2	White 2
9			Red 3
10			Green 3
11			Blue 3
12			White 3
13			Red 4
14			Green 4
15			Blue 4
16			White 4
17			Red 5
18			Green 5
19			Blue 5
20			White 5
21			Red 6
22			Green 6
23			Blue 6
24			White 6
25			Red 7
26			Green 7
27			Blue 7
28			White 7

Bas	FX	Std	Ext	Function	DMX Value	Default
1	1	1	1	PAN Lineary from 0% to 100%	000 ÷ 255	128
2	2	2	2	PAN FINE Lineary from 0% to 100%	000 ÷ 255	128
3	3	3	3	TILT Lineary from 0% to 100%	000 ÷ 255	128
4	4	4	4	TILT FINE Lineary from 0% to 100%	000 ÷ 255	128
5	5	5	5	DIMMER Lineary from close to open	000 ÷ 255	000
6	6	6	6	DIMMER FINE Lineary from close to open	000 ÷ 255	000
7	7	7	7	SHUTTER Close Strobe from slow to fast Open Pulse in from slow to fast Open Pulse out from slow to fast Open Random from slow to fast Open	000 ÷ 001 002 ÷ 062 063 ÷ 064 065 ÷ 125 126 ÷ 127 128 ÷ 188 189 ÷ 190 191 ÷ 251 252 ÷ 255	255
8	8	8	8	RED Lineary from 0% to 100%	000 ÷ 255	255
		9	9	RED FINE Lineary from 0% to 100%	000 ÷ 255	255
9	9	10	10	GREEN Lineary from 0% to 100%	000 ÷ 255	255
		11	11	GREEN FINE Lineary from 0% to 100%	000 ÷ 255	255
10	10	12	12	BLUE Lineary from 0% to 100%	000 ÷ 255	255
		13	13	BLUE FINE Lineary from 0% to 100%	000 ÷ 255	255
11	11	14	14	WHITE Lineary from 0% to 100%	000 ÷ 255	255
		15	15	WHITE FINE Lineary from 0% to 100%	000 ÷ 255	255
12		16	16	COLOR MACRO Open Red Green Blue Cyan Magenta Yellow Dirty White Alice Bllue Congo Blue Dark Steel Blue Deep Lavender Lilac Ting Daylight Blue Flame Red Bastard Amber Deep Orange Pale Gold Apricot Bright Blue Primary Green Special Lavender Pale Lavender Deep Golden Amber Medium Blue Bright Pink Mauve Dark Green Lee Green Dark Blue	000 ÷ 001 002 ÷ 003 004 ÷ 005 006 ÷ 007 008 ÷ 009 010 ÷ 011 012 ÷ 013 014 ÷ 015 016 ÷ 017 018 ÷ 019 020 ÷ 021 022 ÷ 023 024 ÷ 025 026 ÷ 027 028 ÷ 029 030 ÷ 031 032 ÷ 033 034 ÷ 035 036 ÷ 037 038 ÷ 039 040 ÷ 041 042 ÷ 043 044 ÷ 045 046 ÷ 047 048 ÷ 049 050 ÷ 051 052 ÷ 053 054 ÷ 055 056 ÷ 057 058 ÷ 059	000

Bas	FX	Std	Ext	Function	DMX Value	Default
12		16	16	COLOR MACRO		
				Light Blue	060 ÷ 061	
				Steel Blue	062 ÷ 063	
				Medium Blue+Green	064 ÷ 065	
				Peacock Blue	066 ÷ 067	
				Magenta	068 ÷ 069	
				Dark Pink	070 ÷ 071	
				Middle Rose	072 ÷ 073	
				Light Salmon	074 ÷ 075	
				English Rose	076 ÷ 077	
				Light Rose	078 ÷ 079	
				Orange	080 ÷ 081	
				Deep Amber	082 ÷ 083	
				Straw	084 ÷ 085	
				Light Amber	086 ÷ 087	
				Spring Yellow	088 ÷ 089	
				Dark Yellow Green	090 ÷ 091	
				Just Blue	092 ÷ 093	
				Sky Blue	094 ÷ 095	
				Lavender	096 ÷ 097	
				Light Lavender	098 ÷ 099	
				Pink Carnation	100 ÷ 101	
				Medium Pink	102 ÷ 103	
				Light Pink	104 ÷ 105	
				Sunset Red	106 ÷ 107	
				Dark Amber	108 ÷ 109	
				Gold Amber	110 ÷ 111	
				Medium Amber	112 ÷ 113	
				Fire	114 ÷ 115	
				Surprise Peach	116 ÷ 117	
				Straw Tint	118 ÷ 119	
				Medium Yellow	120 ÷ 121	
				Lee Minus Green	122 ÷ 123	
				Pale Gold	124 ÷ 125	
				Orange	126 ÷ 127	
				Deep Straw	128 ÷ 129	
				Rose Purple	130 ÷ 131	
				Deep Purple	132 ÷ 133	
				Soft Green	134 ÷ 135	
				Reserved	136 ÷ 211	
				2800K	212 ÷ 213	
3000K	214 ÷ 215					
3200K	216 ÷ 217					
3400K	218 ÷ 219					
3600K	220 ÷ 221					
3800K	222 ÷ 223					
4000K	224 ÷ 225					
4200K	226 ÷ 227					
4400K	228 ÷ 229					
4600K	230 ÷ 231					
4800K	232 ÷ 233					
5000K	234 ÷ 235					
5200K	236 ÷ 237					
5400K	238 ÷ 239					
5600K	240 ÷ 241					
6000K	242 ÷ 243					
6500K	244 ÷ 245					
7000K	246 ÷ 247					
8000K	248 ÷ 249					
9000K	250 ÷ 251					
10000K	252 ÷ 253					
Full On	254 ÷ 255					
13	12	17	17	CCT Linear from 2800K to 10000K	000 ÷ 255	000
14	13	18	18	ZOOM Lineary from 0% to 100%	000 ÷ 255	000
		19	19	ZOOM FINE Lineary from 0% to 100%	000 ÷ 255	000
15	14	20	20	CROSSFADE PIXEL ENGINE PROTOCOL Fades from 1 st to 2 nd protocol according to the combination choosed	000 ÷ 255	000

Bas	FX	Std	Ext	Function	DMX Value	Default
16	15	21	21	CROSSFADE FROM COLOR ENGINE TO PIXEL ENGINE Linear from Color Engine to Pixel Engine	000 ÷ 255	000
17	16	22	22	CROSSFADE FROM WHITE TO COLOR Linear from CCT to Color engine	000 ÷ 255	255
18	17	23	23	CONTROL No Function KLINGNET ON KLINGNET OFF PAN REVERSE ON PAN REVERSE OFF TILT REVERSE ON TILT REVERSE OFF PAN/TILT MODE FAST PAN/TILT MODE MEDIUM PAN/TILT MODE SLOW PAN/TILT MODE SYNC MOVEMENT IN BLACKOUT ON MOVEMENT IN BLACKOUT OFF HOME POSITION STANDARD HOME POSITION CUSTOM DISPLAY ON DISPLAY 10S DISPLAY 20S DISPLAY 30S FLIP DISPLAY ON FLIP DISPLAY OFF FLIP DISPLAY AUTO KEY LOCK ON KEY LOCK OFF FAN MODE AUTO FAN MODE SILENT FAN MODE HIGH WHITE CALIBRATION OFF WHITE CALIBRATION STUDIO WHITE CALIBRATION 8000K NO SIGNAL HOLD NO SIGNAL BLACKOUT STATUS LED ON STATUS LED OFF DIMMER CURVE LINEAR DIMMER CURVE S+CURVE DIMMER CURVE SQUARE LAW DIMMER CURVE INVERSE SQUARE LAW DIMMER SPEED AUTO DIMMER SPEED FAST DIMMER SPEED MEDIUM DIMMER SPEED SLOW LED FREQUENCY 600HZ LED FREQUENCY 1200HZ LED FREQUENCY 2000HZ LED FREQUENCY 4000HZ LED FREQUENCY 6000HZ LED FREQUENCY 25KHZ LED FREQUENCY 50KHZ INVERT MAPPING ON INVERT MAPPING OFF ZOOM MODE STANDARD ZOOM MODE PIXELS INVERT ZOOM OFF INVERT ZOOM ON TUNGSTEN EMULATION ON TUNGSTEN EMULATION OFF RESET ALL RESET PAN RESET TILT RESET PAN/TILT RESET ZOOM Reserved ETH TO DMX OFF ETH TO DMX ON (MAIN FIXTURE TO DMX) ETH TO DMX ON (PIXEL ENGINE TO DMX) WDMX TO DMX OFF WDMX TO DMX ON IN TO WDMX OFF IN TO WDMX ON (MAIN FIXTURE TO WDMX) IN TO WDMX ON (PIXEL ENGINE TO WDMX) SAFE POSITIONING ON SAFE POSITIONING OFF Reserved FACTORY DEFAULT OF CONTROL FUNCTIONS	000 ÷ 001 002 ÷ 003 004 ÷ 005 006 ÷ 007 008 ÷ 009 010 ÷ 011 012 ÷ 013 014 ÷ 015 016 ÷ 017 018 ÷ 019 020 ÷ 021 022 ÷ 023 024 ÷ 025 026 ÷ 027 028 ÷ 029 030 ÷ 031 032 ÷ 033 034 ÷ 035 036 ÷ 037 038 ÷ 039 040 ÷ 041 042 ÷ 043 044 ÷ 045 046 ÷ 047 048 ÷ 049 050 ÷ 051 052 ÷ 053 054 ÷ 055 056 ÷ 057 058 ÷ 059 060 ÷ 061 062 ÷ 063 064 ÷ 065 066 ÷ 067 068 ÷ 069 070 ÷ 071 072 ÷ 073 074 ÷ 075 076 ÷ 077 078 ÷ 079 080 ÷ 081 082 ÷ 083 084 ÷ 085 086 ÷ 087 088 ÷ 089 090 ÷ 091 092 ÷ 093 094 ÷ 095 096 ÷ 097 098 ÷ 099 100 ÷ 101 102 ÷ 103 104 ÷ 105 106 ÷ 107 108 ÷ 109 110 ÷ 111 112 ÷ 113 114 ÷ 115 116 ÷ 117 118 ÷ 119 120 ÷ 121 122 ÷ 123 124 ÷ 125 126 ÷ 127 128 ÷ 129 130 ÷ 131 132 ÷ 133 134 ÷ 135 136 ÷ 137 138 ÷ 139 140 ÷ 141 142 ÷ 143 144 ÷ 145 146 ÷ 253 254 ÷ 255	000

Bas	FX	Std	Ext	Function	DMX Value	Default
		24	24	CTO ON COLORS Lineary from 0% to 100%	000 ÷ 255	000
		25	25	TINT +25 % to +0 % magenta balanced +0 % to +25 % green	000 ÷ 127 128 129 ÷ 255	128
	18		26	PATTERN No FX All rings In & Out All rings In & Out Bouncing Single Ring In & Out Single Ring In & Out Bouncing All Pixels In & Out in Right Direction Single Line In & Out in Right Direction Single Line In & Out Bouncing in Left / Right Direction All Pixels In & Out in Bottom Direction Single Line In & Out in Bottom Direction Single Line In & Out Bouncing in Top / Bottom Direction Half Pixels rotating clockwise Fixture divided into 2 parts ring effect Random with 1px Density Random with 2px Density Random with 4px Density Random with 5px Density Random with 7px Density Pixel Going around Ring 1 Pixel Going around Ring 1 Pixel Going around Ring 2 Pixel Going around Ring 2 Pixel Going around Ring 2 Pixel Going around Ring 2 Clock rotating anti-clockwise Two squares rotating while moving from center Wiggling Line Two rotating 2x2px squares Pixels In & Out on Ring 2 side to side Triangle from 9 pixels rotate to right Wiggling clock 2 hands moving up and down Aperture effect Aperture Effect with 1 px only 2 Pixels Going around Ring 2 3 Pixels Going around Ring 2 Bottom Half Open / Close than Top Half Open Close Moving Fists Pixels coming in zigzak shape 2 Arc's rotating 2 2px wide lines rotating	000 ÷ 016 017 ÷ 022 023 ÷ 028 029 ÷ 034 035 ÷ 040 041 ÷ 046 047 ÷ 052 053 ÷ 058 059 ÷ 064 065 ÷ 070 071 ÷ 076 077 ÷ 082 083 ÷ 088 089 ÷ 094 095 ÷ 100 101 ÷ 106 107 ÷ 112 113 ÷ 118 119 ÷ 124 125 ÷ 130 131 ÷ 136 137 ÷ 142 143 ÷ 148 149 ÷ 154 155 ÷ 160 161 ÷ 166 167 ÷ 172 173 ÷ 178 179 ÷ 184 185 ÷ 190 191 ÷ 196 197 ÷ 202 203 ÷ 208 209 ÷ 214 215 ÷ 220 221 ÷ 226 227 ÷ 232 233 ÷ 238 239 ÷ 244 245 ÷ 250 251 ÷ 255	000
	19		27	PATTERN SPEED Indexing CW from fast to slow Stop CCW from slow to fast	000 ÷ 127 128 ÷ 190 191 ÷ 192 193 ÷ 255	000
	20		28	PATTERN FADE Lineary from 0% to 100%	000 ÷ 255	000
	21		29	PATTERN TRANSITION Lineary from 0% to 100%	000 ÷ 255	000
	22		30	FOREGROUND INTENSITY Lineary from 0% to 100%	000 ÷ 255	000
	23		31	FOREGROUND STROBE Close Strobe from slow to fast Open Pulse in from slow to fast Open Pulse out from slow to fast Open Random from slow to fast Open	000 ÷ 001 002 ÷ 062 063 ÷ 064 065 ÷ 125 126 ÷ 127 128 ÷ 188 189 ÷ 190 191 ÷ 251 252 ÷ 255	255

Bas	FX	Std	Ext	Function	DMX Value	Default
	24		32	BACKGROUND INTENSITY Lineary from 0% to 100%	000 + 255	000
	25		33	BACKGROUND STROBE Close Strobe from slow to fast Open Pulse in from slow to fast Open Pulse out from slow to fast Open Random from slow to fast Open	000 + 001 002 + 062 063 + 064 065 + 125 126 + 127 128 + 188 189 + 190 191 + 251 252 + 255	255
	26		34	BACKGROUND RED Lineary from 0% to 100%	000 + 255	000
	27		35	BACKGROUND GREEN Lineary from 0% to 100%	000 + 255	000
	28		36	BACKGROUND BLUE Lineary from 0% to 100%	000 + 255	000
	29		37	BACKGROUND WHITE Lineary from 0% to 100%	000 + 255	000

13 - RING LAYOUT

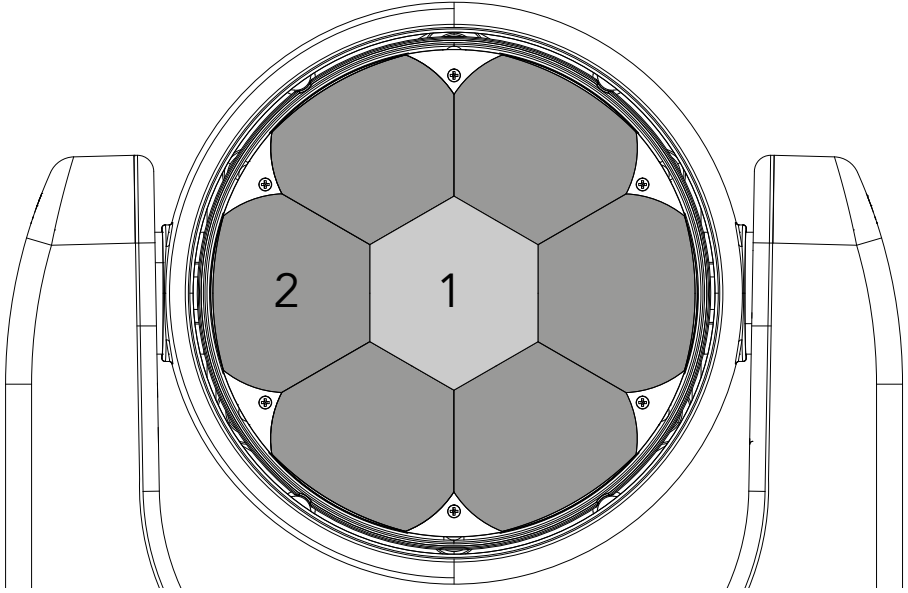

Fig. 08

14 - PIXEL LAYOUT

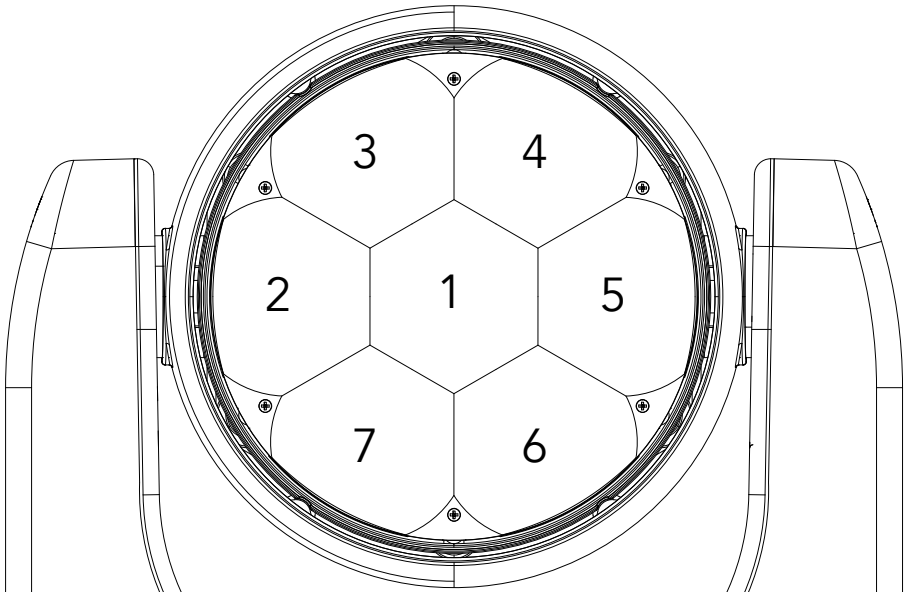

Fig. 09

15 - ERROR MESSAGES

The error is shown on the unit display. In the table below, the "ERROR SHOWED ON SCREEN" column lists the possible errors, accompanied by a possible cause ("POSSIBLE" CAUSES "column).

The color of the error messages (listed in the "COLOR MESSAGES" column) is different for each board it refers to ("PCB" column).

On page 30 you can see the location of the various pcb boards.

ERROR SHOWED ON SCREEN	POSSIBLE CAUSES	COLOUR MESSAGES	PCB
[DISPLAY BATTERY ERROR]	Battery not present or not detected from the display PCB.	Green	1U
[BASE FAN ERROR]	Blower for cooling base failed.	Green	1U
[DMX ACTIVE]	If transfer configuration is used with dmx signal connected.	Green	1U
[MAINTENANCE TIME]	Need to be done standard maintenance and also reset of elapsed time.	Green	1U
[PAN/TILT PCB ERROR]	Pan tilt pcb not detected.	Blue	2U
[PAN MOTOR ERROR]	This message will appear after the reset of the product if: <ul style="list-style-type: none"> the PAN magnetic-indexing circuit detect a failure (sensor failed or magnet is missing); or the stepping motor is defective; or its driving IC on the PCB is defective; or the product is not located in the default position after the reset of the fixture. 	Blue	2U
[TILT MOTOR ERROR]	This message will appear after the reset of the product if: <ul style="list-style-type: none"> the TILT magnetic-indexing circuit detect a failure (sensor failed or magnet is missing); or the stepping motor is defective; or its driving IC on the PCB is defective; or the product is not located in the default position after the reset of the fixture. 	Blue	2U
[PAN SENSOR ERROR]	Pan sensor not detected.	Blue	2U
[TILT SENSOR ERROR]	Tilt sensor not detected.	Blue	2U
[PAN ENCODER ERROR]	Pan encoder not detected.	Blue	2U
[TILT ENCODER ERROR]	Tilt encoder not detected.	Blue	2U
[LED FAN ERROR]	One of the blowers for cooling the source failed, the source has been switched OFF.	Blue	3U
[DRIVER/LED PCB ERROR]	Led driver pcb not detected	Yellow	3U
[ZOOM ERROR]	Failure detected during the reset of the ZOOM system, if the zoom lens is not located in its default position.	Yellow	3U
[LED DRIVER TEMPERATURE ERROR]	This error message indicates that an overheating in the head has occurred and the lamp has been switched OFF by the product protection system.	Yellow	3U
[LED PCB ERROR]	LED PCB 1 not detected during reset	Yellow	3U

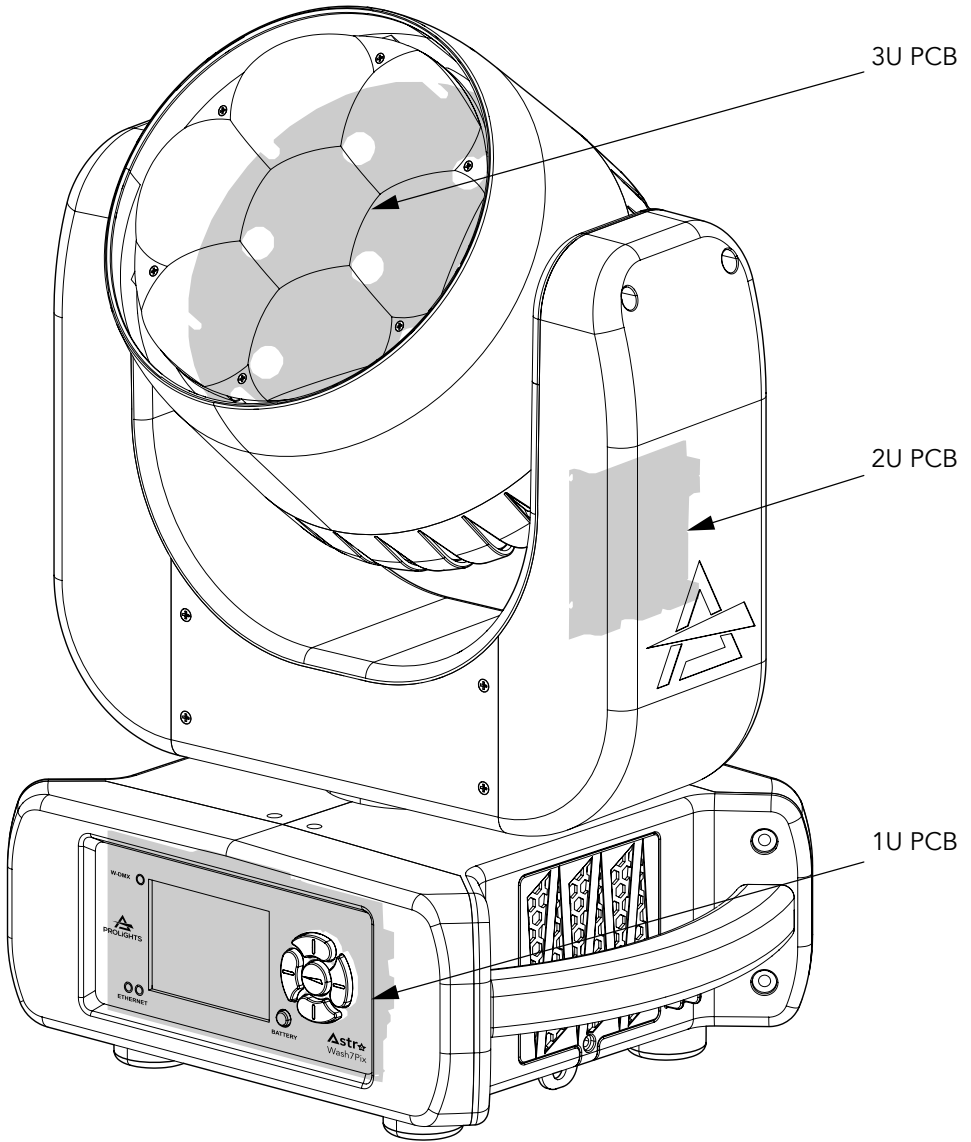
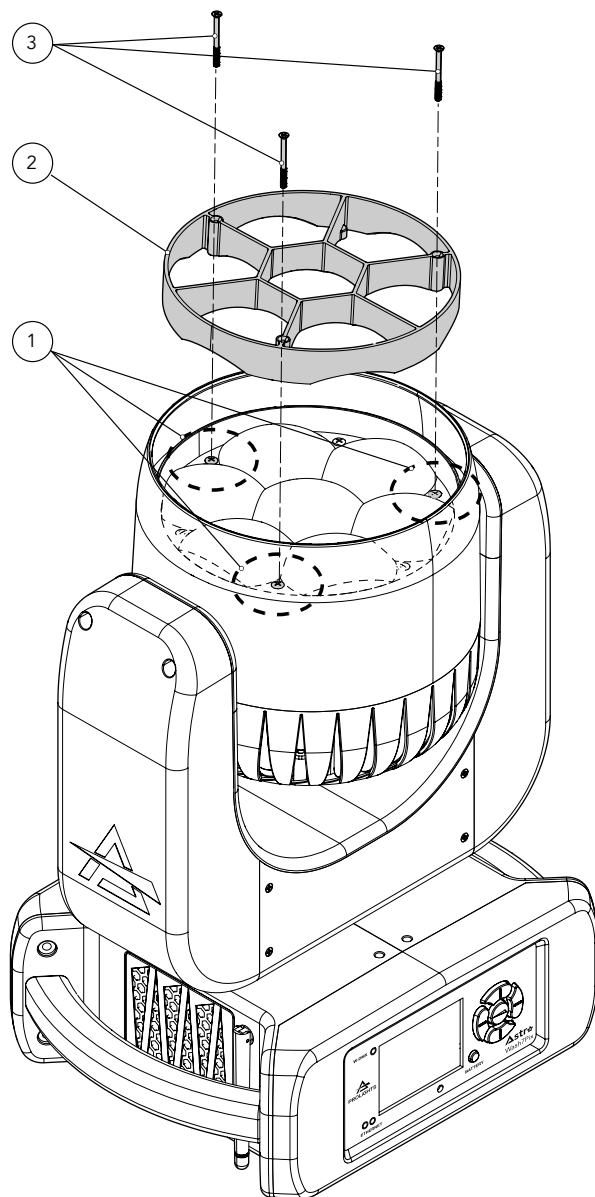

Fig. 10

16 - ACCESSORIES INSTALLATION

EGG CRATE (ASTRAW7PEC - OPTIONAL)



Loosen and remove the marked three screws (1). Then insert the egg crate (2) and fix the three screws (3).

Fig. 11

17 - PERIODICAL CLEANING

WARNING! Turn OFF power and allow approximately 20 minutes for the fixture to cool down.

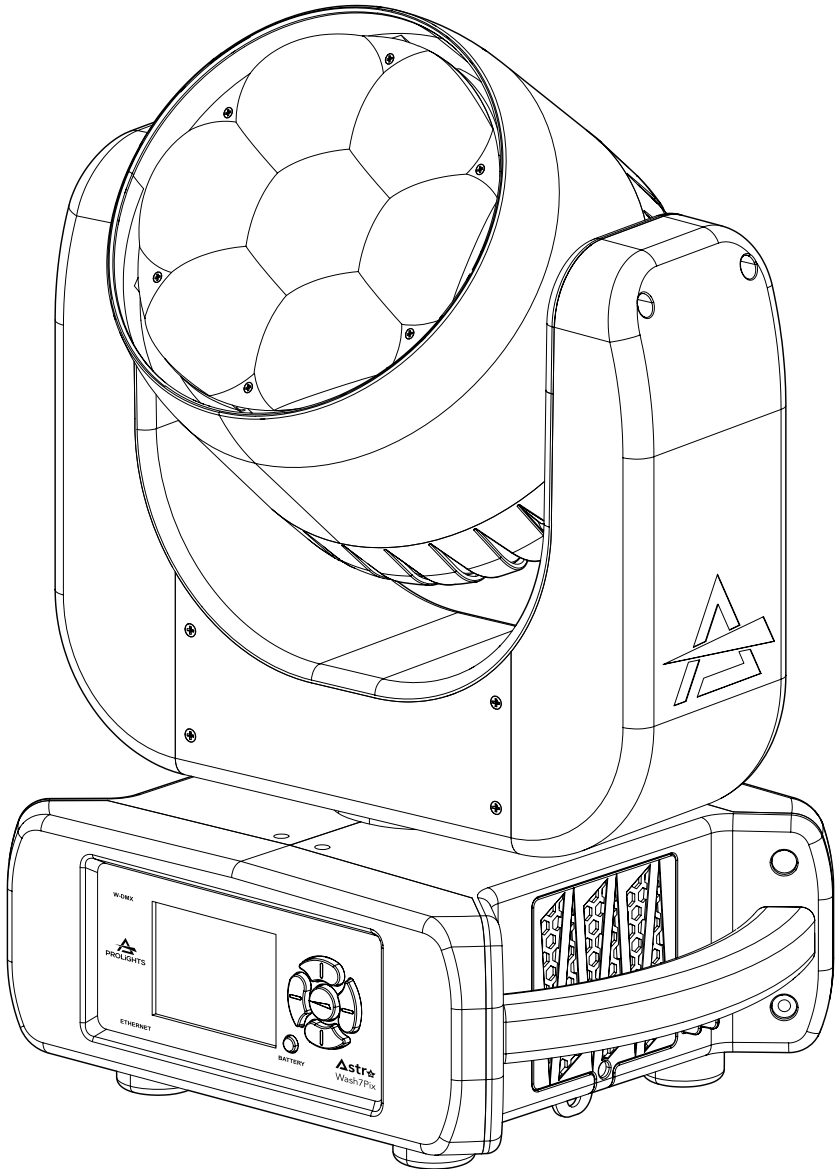

Use a soft cloth dampened with any detergent liquid for cleaning to remove the dirt from the optics.

Fig. 12

18 - MAINTENANCE

MAINTENANCE AND CLEANING THE PRODUCT

WARNING: Disconnect from the mains before starting any maintenance work

It is recommended to clean the front at regular intervals, from impurities caused by dust, smoke, or other particles to ensure that the light is radiated at maximum brightness.

- For cleaning, disconnect the main plug from the socket. Use a soft, clean cloth moistened with a mild detergent. Then carefully wipe the part dry. For cleaning other housing parts use only a soft, clean cloth. Never use a liquid, it might penetrate the unit and cause damage to it.
- The user must clean the product periodically to maintain optimum performance and cooling. The user may also upload firmware (product software) to the fixture via the DMX signal input port or USB port using firmware and instructions from PROLIGHTS.
- The frequency of such maintenance operations is to be performed according to various factors, such as the amount of the use and the condition of the installation environment (air humidity, presence of dust, salinity, etc.). It is recommended that the product is subject to annual service by a qualified technician for special maintenance involving at least the following procedures:
 - General cleaning of internal parts.
 - For all the parts subject to friction, using lubricants specifically supplied by PROLIGHTS.
 - General visual check of the internal components, cabling, mechanical parts, etc.
 - Electrical, photometric and functional checks; eventual repairs.
 - Cleaning the lenses. Only use neutral soap and water to clean the lenses, then dry it carefully with a soft, non-abrasive cloth.

WARNING: the use of alcohol or any other detergent could damage the lenses.

- All other service operations on the product must be carried out by PROLIGHTS, its approved service agents or trained and qualified personnel.
- It is PROLIGHTS policy to apply the strictest possible calibration procedures and use the best quality materials available to ensure optimum performance and the longest possible component lifetimes. However, optical components are subject to wear and tear over the life of the product, resulting in gradual changes in colours over many thousands of hours of use. The extent of wear and tear depends heavily on operating conditions and environment, so it is impossible to specify precisely whether and to what extent performance will be affected. However, you may eventually need to replace optical components if their characteristics are affected by wear and tear after an extended period of use and if you require fixtures to perform within very precise optical and colour parameters.
- Do not apply filters, lenses or other materials on lenses or other optical components. Use only accessories approved by PROLIGHTS.

REPLACING THE FUSE

WARNING: Before replacing the fuse, unplug the product from the mains.

- Remove the old fuse from the housing with a suitable screwdriver (anticlockwise) and replace it with one of the same type and of the same classification (T3.15A 250V).

VISUAL CHECK OF PRODUCT HOUSING

- The parts of the product cover/housing should be checked for eventual damages and breaking start at least every two months. In addition, especially the parts of the front lens holder have to be checked mechanically (by means of movement by the part) if it is firmly fastened to the fixture. If hint of a crack is found on some plastic part, do not use the product until the damaged part will be replaced.
- Cracks or another damages of the cover/housing parts can be caused by the product transportation or manipulation and also ageing process may influence materials.
- This checking is necessary for both fixed installations and preparing product for renting. Any free moving parts inside of the product, cracked cover/housing or any part of front lens not sitting properly in place need to be immediately replaced.

TROUBLESHOOTING

Problems	Possible causes	Checks and remedies
Product doesn't power ON.	<ul style="list-style-type: none"> No power to the product. 	<ul style="list-style-type: none"> Check that power is switched ON and cables are plugged in.
	<ul style="list-style-type: none"> Fuse blown or internal fault. 	<ul style="list-style-type: none"> Check if the Fuse is intact and eventually replace it if necessary. Contact the PROLIGHTS Service or authorized service partner. Do not remove parts and/or covers, or carry out any repairs or service that are not described in this Safety and User Manual unless you have both authorization from PROLIGHTS and the service documentation.
Product reset correctly but does not respond correctly to the controller.	<ul style="list-style-type: none"> Bad signal connection. 	<ul style="list-style-type: none"> Inspect connections and cables. Fix eventual bad connections. Repair or replace damaged cables.
	<ul style="list-style-type: none"> Signal connection not terminated. 	<ul style="list-style-type: none"> Insert DMX termination plug in signal output socket of the last product on the signal line.
	<ul style="list-style-type: none"> Incorrect addressing of the product. 	<ul style="list-style-type: none"> Check the product address and control settings.
	<ul style="list-style-type: none"> One of the product is defective and is corrupting the signal transmission on the signal line. 	<ul style="list-style-type: none"> Unplug the XLR in and out connectors and connect them directly together to bypass one product at a time until normal operation is regained. Once found the error, have that fixture serviced by a qualified technician.
Timeout error after fixture reset.	<ul style="list-style-type: none"> One or more hardware components requires mechanical adjustments. 	<ul style="list-style-type: none"> Check product stored error messages for more information. Contact PROLIGHTS Service or an authorized service partner.
Mechanical effect loses position.	<ul style="list-style-type: none"> Mechanical hardware require cleaning, adjustment or lubrication. 	<ul style="list-style-type: none"> Check product stored error messages for more information. Contact PROLIGHTS Service or an authorized service partner.
Light output turn OFF Intermittently.	<ul style="list-style-type: none"> Fixture is too hot. 	<ul style="list-style-type: none"> Check product stored error messages. Allow product to cool. Clean the product and airflow filters. Reduce ambient temperature.
	<ul style="list-style-type: none"> Hardware failure (temperature sensor, fans, Light source...). 	<ul style="list-style-type: none"> Check product stored error messages for more information. Contact PROLIGHTS Service or an authorized service partner.
General low light intensity.	<ul style="list-style-type: none"> Dirty lens assembly. 	<ul style="list-style-type: none"> Clean the fixture regularly.
	<ul style="list-style-type: none"> Dirty or damaged filters. 	<ul style="list-style-type: none"> Install lens assembly properly.

Contact an authorized service center in case of technical problems or not reported in the table can not be resolved by the procedure given in the table.



PROLIGHTS is a trademark of
MUSIC & LIGHTS S.r.l.
musiclights.it

Via A.Olivetti snc
04026 - Minturno (LT) ITALY
Tel: +39 0771 72190

prolights.it
support@prolights.it